LSE445

SERIE DI FRESE PER SPIANATURA CON INSERTI POSITIVI
A 20° PER LAVORAZIONI AFFIDABILI ED EFFICIENTI



*M*plus...

LSE445



SPIANATURA A 45° GENERICA

P M K N



C H: 45°
A.R: +19° T: +13°
RR: -2° I: +15°

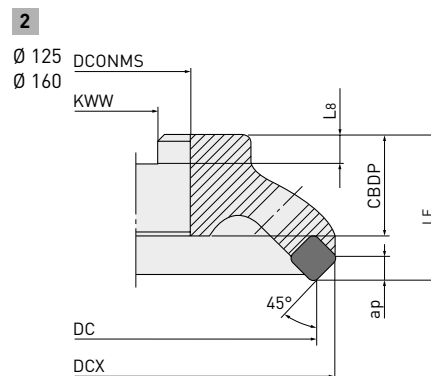
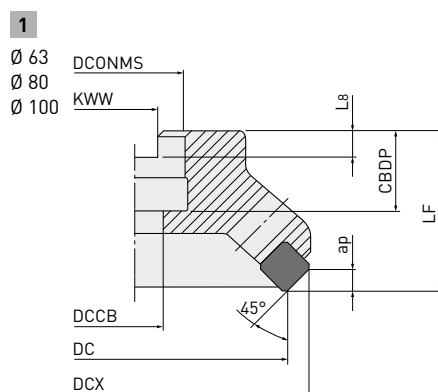

TIPO AD ALBERO

Codice ordinazione	Disponibilità		ZEFP	DC	DCX	LF	DCONMS	CBDP	DCCB	KWW	L8	WT	APMX		Tipo
	R	L													
LSE445-063A05R/L-E	●	□	5	63	76.5	40	22	20	11	10.4	6.4	0.8	5.5	—	1
LSE445-080A06R/L-E	●	□	6	80	93.5	50	27	22	13.5	12.4	7.0	1.0	5.5	—	1
LSE445-100A07R/L-E	●	□	7	100	113.5	50	32	25	17.5	14.4	8.0	1.4	5.5	—	1
LSE445-125B09R/L-E	□	□	9	125	138.5	50	40	32	—	16.4	9.0	2.0	5.5	—	2
LSE445-160B11R/L-E	□	□	11	160	173.5	50	40	32	—	16.4	9.0	3.0	5.5	—	2

1/1



RICAMBI

Numero del portautensile						
	Spessore	Vite per spessore	Cuneo	Vite di fissaggio	Chiave	Chiave
LSE445 -063A05R/L-E				LS10T		
LSE445 -080A04R/L-E						
LSE445-100A07R/L-E	STBE445NF	CS300890T	CWSE445TR	LS15T	TKY25T	TKY08F
LSE445-125B09R/L-E						
LSE445 -160B11R/L-E						

*1 Coppia di serraggio (N • m) : LS10T= 8.5. LS15T= 8.5. CS300890T= 1.0

LSE445 - INSERTI

Material	Legend	Legend	Legend	Legend	Legend	Legend	Legend	Legend	Legend	Legend	Legend	Legend	Legend	Legend	Legend	Legend	Legend	Legend	Legend	Legend	Legend	Legend	
P Acciaio	●	●		●	●	●	●	●	●	●	●	●	●	●	●	●	●	●	●	●	●	●	●
M Acciaio inossidabile	●	●		●	●	●	●	●	●	●	●	●	●	●	●	●	●	●	●	●	●	●	●
K Ghisa				●	●	●	●	●	●	●	●	●	●	●	●	●	●	●	●	●	●	●	●
N Metallo non ferroso	●																						

Parametri di taglio (Guida):
 ●: Taglio stabile ●: Taglio generico ✖: Taglio instabile

Onatura:
 E: Tondo F: Affilato S: Smusso + Onatura T: Smusso Z: Forte

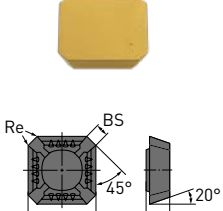
Codice ordinazione	Classe	Onatura	F7010	F7030	MC5020	VP15TF	NX2525	NX4545	UT120T	HT10	IC	S	BS	RE	Forma
SEEN1203AFFN1	E	F	●							●	12.7	3.18	1.4	1.0	
SEEN1203AFEN1	E	E				●					12.7	3.18	1.4	1.0	
SEEN1203AFTN1	E	T	●				●	●			12.7	3.18	1.4	1.0	
SEEN1203AFTN3	E	T	●				●	★			12.7	3.18	1.4	—	
SEEN1203AFSN1	E	S		●	●						12.7	3.18	1.4	1.0	
SEEN1203AFSN3	E	S		●							12.7	3.18	1.4	—	
SEEN1203AFZN1	E	Z					●				12.7	3.18	1.4	1.0	

Inserti con rompitruciolo

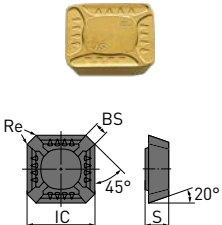
SEER1203AFEN-JS	E	E	●	●	●	●					12.7	3.18	1.4	1.0	
SEER1204AFEN-JS	E	E	●								12.7	3.18	1.4	1.0	

Inserto raschiante

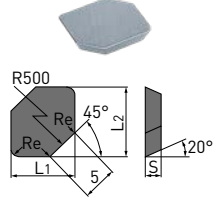
WEC42AFTR5C	C	T					●				—	3.18	5	1.0	
-------------	---	---	--	--	--	--	---	--	--	--	---	------	---	-----	---

1/1



LSE445

PARAMETRI DI TAGLIO CONSIGLIATI

Materiale	Durezza	Grado	Vc	fz
P Acciaio dolce	<180HB	F7030	300 (200 – 360)	0.2 (0.1 – 0.3)
		NX4545		
		UTi20T	240 (170 – 300)	
		UP20M		
P Acciaio al carbonio Acciaio legato	180 – 280HB	F7030	250 (170 – 300)	0.2 (0.1 – 0.3)
		NX4545		
		UTi20T	200 (140 – 240)	
		UP20M		
M Acciaio inossidabile	<200HB	UTi20T	140 (100 – 170)	0.15 (0.1 – 0.2)
		UP20M		
K Ghisa	Resistenza alla trazione <450MPa	MC5020	200 (130 – 240)	0.2 (0.1 – 0.3)
		F5010		
		F5020		
		HTi10	160 (110 – 190)	
		UTi20T		
N Lega di alluminio	—	MD220	1000 (200 – 1500)	0.15 (0.05 – 0.25)
		HTi10	1000 (700 – 1200)	0.12 (0.05 – 0.2)

1/1

1. Numero di giri (min⁻¹) = (1000 x velocità di taglio) ÷ (3.14 x ØD1).

2. Avanzamento della tavola (mm/min) = avanzamento per dente x numero di denti x numero di giri della fresa.





GERMANY

MMC HARTMETALL GMBH
Comeniusstr. 2 . 40670 Meerbusch
Phone +49 2159 91890 . Fax +49 2159 918966
Email admin@mmchg.de

U.K. Office

MMC HARDMETAL U.K. LTD.
Part First Floor, 1 Centurion Court
Centurion Way, Tamworth, B77 5PN
Phone +44 1827 312312
Email sales@mitsubishicarbide.co.uk

U.K. Deliveries/Returns

Unit 4 B5K Business Park, Quartz Close
Tamworth, B77 4GR

SPAIN

MITSUBISHI MATERIALS ESPAÑA, S.A.
Calle Emperador 2 . 46136 Museros/Valencia
Phone +34 96 1441711
Email comercial@mmevalencia.es

FRANCE

MMC METAL FRANCE S.A.R.L.
6, Rue Jacques Monod . 91400 Orsay
Phone +33 1 69 35 53 53 . Fax +33 1 69 35 53 50
Email mmfsales@mmc-metal-france.fr

POLAND

MMC HARDMETAL POLAND SP. Z O.O
Al. Armii Krajowej 61 . 50-541 Wrocław
Phone +48 71335 1620 . Fax +48 71335 1621
Email sales@mitsubishicarbide.com.pl

ITALY

MMC ITALIA S.R.L.
Viale Certosa 144 . 20156 Milano
Phone +39 0293 77031 . Fax +39 0293 589093
Email info@mmc-italia.it

TURKEY

MMC HARTMETALL GMBH ALMANYA - İZMİR MERKEZ ŞUBESİ
Adalet Mahallesi Anadolu Caddesi No: 41-1 . 15001 35530 Bayraklı / İzmir
Phone +90 232 5015000 . Fax +90 232 5015007
Email info@mmchg.com.tr

europe.mmc-carbide.com

DISTRIBUITO DA:

┌

┐

└

┘

MP1031 

MMC Hartmetall GmbH – A Sales Company of MITSUBISHI MATERIALS | 2024.01